

Micro tablet dosing unit

for counting and dosing small homogeneous tablets

MTD324



Pharmaceutical industry



Chemicals industry



Range of products:

small homogeneous tablets

for pharmaceutical and chemical applications

Amount per dosing is freely adjustable – up to 3500 tablets per minute
-depending on the product and amount per dosing!

Micro tablet dosing unit

Type: MTD324

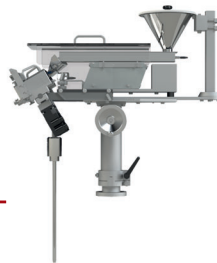

MERZSYSTEM

Verpackungsmaschinen

Description of operation:

The tablets are supplied to the dosing unit by a hopper via a vibration channel. The dosing unit consists of 2 dosing disks which simultaneously

dose into the filling tube of the packaging machine.

While the tablets are falling down, they are counted by two counters which are independent from each other. The second counter verifies the results of the first one.

Just before the selected number of tablets is reached, both disks are slowed down and dose directly, with reduced speed until the exact number of tablets is reached. The counted tablets are dosed onto a closed slider and, after the selected number of tablets has been reached, the tablets are dropped into the stick by opening of the slider. Now the packaging machine can carry out the next cycle independently of the dosing unit.

The cycle starts again after closing of the slider.

Technical data:

Lanes:	1 lane
Output:	up to 3500 tablets / min.*
Colour standard:	stainless steel / alu

* depending on the product and amount per dosing

Technical details:

- ◆ assembly directly onto SB51-1, SB51-2 and SBL50
- ◆ compact, robust, durable design
- ◆ all product touching parts are out of stainless steel or another approved material.
- ◆ little maintenance
- ◆ fast and simple cleaning of the counting disks, since these can be disassembled without any tools.
- ◆ the dosing unit corresponds to the current CE guidelines

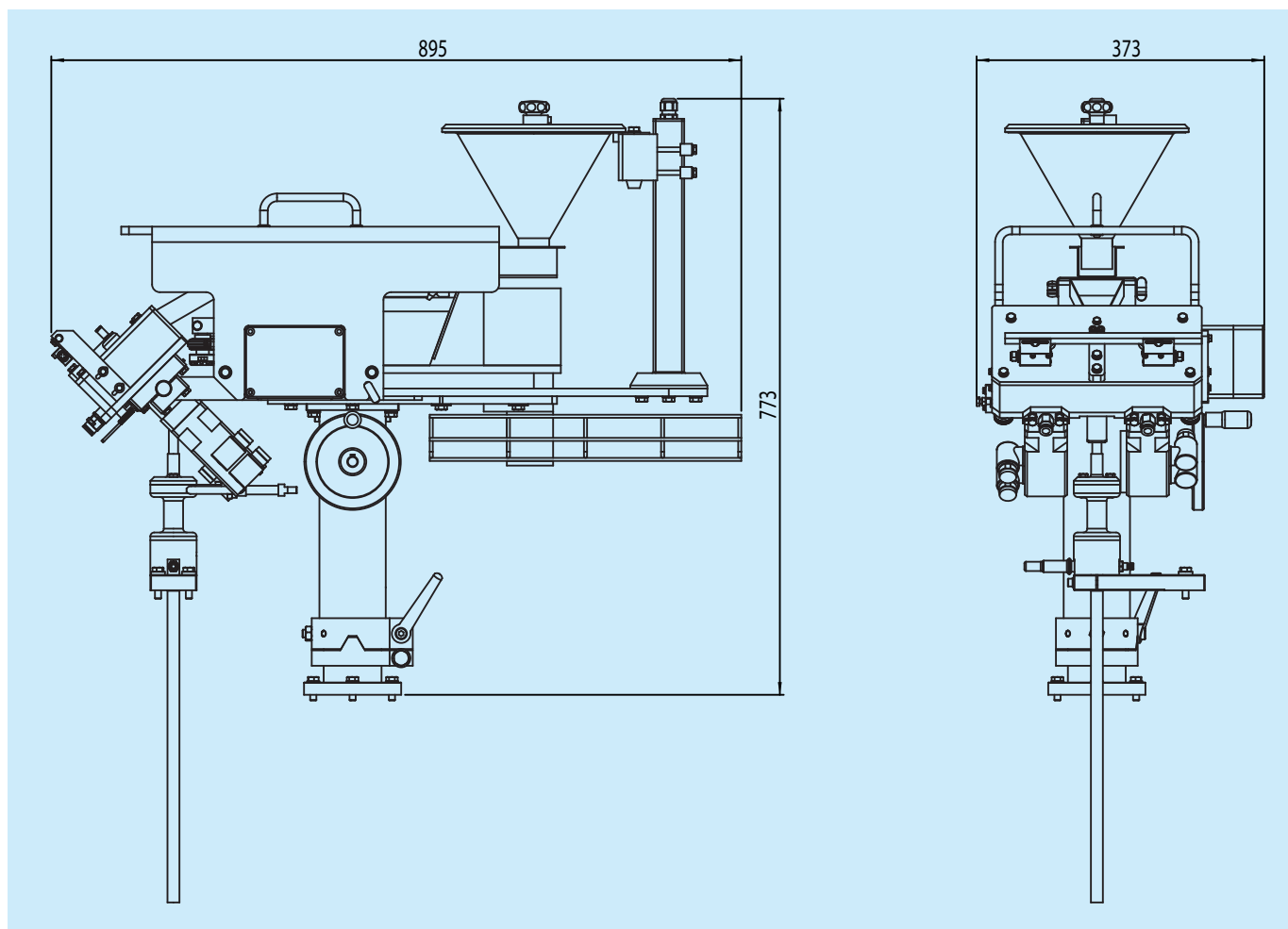

Since 1971



Made in Germany